



Wi.M900X/T-R Drop-In Embedded Wireless Module

868/915 MHz, 152.34kbit/sec, 32/84 channels



Typical Applications

- Automated Meter Reading
- Security Sensors
- Toys
- Remote Control

Description

The Wi.M900X/T module is a microcontroller-less version of our popular Wi.232DTS module. It offers the same excellent RF performance, yet allows the design engineer to control the radio at the physical level using any microcontroller. The module is footprint compatible with the Wi.232DTS module so upgrading to the Wi.232DTS is very easy... no PCB changes are required.

The module supports two modes of operation: wide-band and narrow-band. In wide-band mode, the channel width is 600kHz and in narrow-band mode the channel width is 200kHz.

The module is configured via a simple SPI style serial interface. Data is transmitted and received using a separate digital serial interface that includes pre-amble and start-of-packet detection.

A typical circuit consists of a low-cost microcontroller, a power source, a Wi.M900X/T module, and an antenna.

The WiM900X module is a complete transceiver while the WiM900T module is transmit only. In addition, the modules can be ordered for operation in the 868 MHz band by substituting 868 for 900. For example: WiM868X.

Features

- Instant physical radio solution – no external RF components required
- Simple FCC certification as digital spread spectrum device
- Supports frequency hopping
- Based on the XEMICS XE1203F transceiver
- Footprint compatible with our Wi.232DTS module
- Built data clock recovery
- Automatic packet start detection
- 2.4-3.6 volt operation
- 1.2 – 152.34kbit/second data rate
- SPI style digital serial interface
- Factory set 48-bit unique ID
- Smallest form factor in the world – under 0.8” square
- Maximum output power – +15dBm
- Maximum RF sensitivity – -112dBm
- RF sensitivity @ max data rate – -103dBm typ.
- TX current = 54mA @ 15dBm typical
- RX current = 14mA typical
- NV personality memory stores factory calibration, lot code information, and unique ID
- Can be provided with or without a SAW filter.
- 868, and 915 MHz versions are available
- 32 wideband and 84 narrow band channels are available in the 915 MHz version

Document Control

Document Control

| | | |
|-------------------------------|------------------|----------|
| Created By | Steve Montgomery | 3/4/2005 |
| Engineering Review | | |
| Marketing Review | | |
| Approved – Engineering | | |
| Approved – Marketing | | |

Revision History

| Revision | Author | Date | Description |
|-----------------|---------------|-------------|--------------------|
| 1.0A | SJM | 3/4/2005 | Document Created |
| | | | |
| | | | |
| | | | |
| | | | |
| | | | |

Table of Contents

| | |
|--|----|
| Typical Applications | 1 |
| Features | 1 |
| Description | 1 |
| Document Control | 2 |
| Revision History | 2 |
| Table of Contents..... | 3 |
| Pin-out Diagram | 4 |
| Mechanical Drawing..... | 4 |
| Pin Descriptions | 4 |
| Absolute Maximum Ratings | 5 |
| Detailed Electrical Specifications | 5 |
| AC Specifications – RX | 5 |
| Notes..... | 5 |
| AC Specifications - TX..... | 6 |
| Notes..... | 6 |
| DC Specifications | 6 |
| Notes..... | 6 |
| Functional Description..... | 7 |
| Programming Interface..... | 9 |
| Non-volatile memory | 12 |
| Example circuit..... | 12 |
| Ordering Information | 14 |
| Contact Information..... | 14 |

Pin-out Diagram

Mechanical Drawing

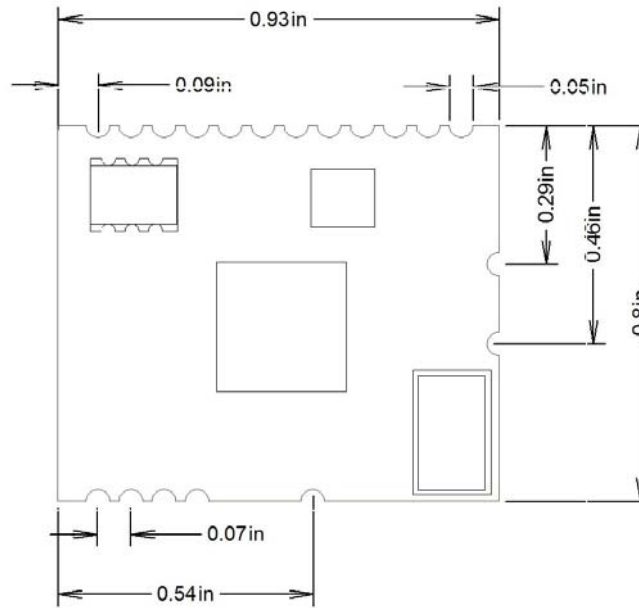
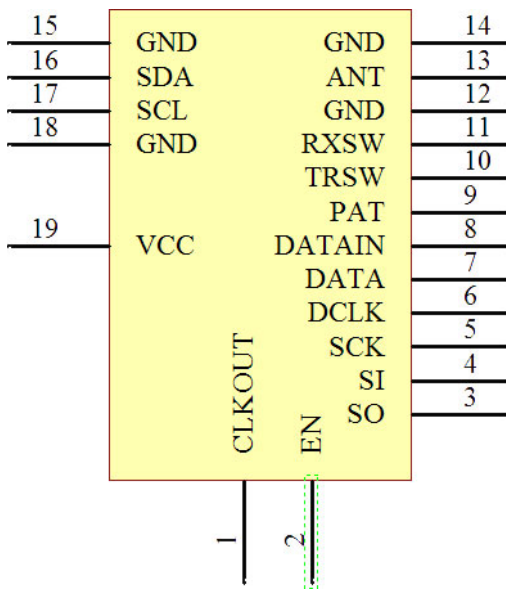

Pin Descriptions

| Pin Number | Name | Description |
|------------|---------|---|
| 1 | CLKOUT | Clock output from XE1203 – GND on Wi.23DTS |
| 2 | EN | XE1203 Programming port enable |
| 3 | SO | XE1203 Programming port serial output |
| 4 | SI | XE1203 Programming port serial input |
| 5 | SCK | XE1203 Programming port clock |
| 6 | DCLK | XE1203 Data port clock |
| 7 | DATA | XE1203 Data input/output – programmable |
| 8 | DATAIN | XE1203 Data input |
| 9 | PAT | XE1203 Pattern output – indicates start-of-packet |
| 10 | SWITCH2 | Transmit enable – controls RF switch |
| 11 | SWITCH1 | Receive enable – controls RF switch – not used in transmit only version |
| 12 | GND | Ground |
| 13 | ANT | 50 ohm antenna power |
| 14 | GND | Ground |
| 15 | GND | Ground |
| 16 | SDA | Serial data pin for NV personality memory – I2C bus |
| 17 | SCL | Serial clock pin for NV personality memory – I2C bus |
| 18 | GND | Ground |
| 19 | VCC | 2.4 – 3.6 volt power supply |

Absolute Maximum Ratings

| Parameter | Min | Max | Units |
|-----------------------|-----|-----|-------|
| VCC – power supply | 0 | 3.9 | VDC |
| Voltage on any pin | 0 | VCC | VDC |
| Input RF level | | -5 | DBm |
| Storage Temperature | -40 | +85 | °C |
| Operating Temperature | -40 | +85 | °C |

Detailed Electrical Specifications

AC Specifications – RX

| Parameter | Min | Typ | Max | Units | Notes |
|----------------------------|-----|------|-----|-------|--|
| Receive Frequency – US | 902 | | 928 | MHz | |
| Receive Frequency – EUR | 868 | | 870 | MHz | |
| Wide band channels – US | 32 | | | | <ul style="list-style-type: none"> 750kHz channel spacing 235kHz deviation |
| Wide band channels – EUR | 2 | | | | <ul style="list-style-type: none"> 400kHz channel spacing 155kHz deviation Channel usage depends on application |
| Narrow band channels – US | 84 | | | | <ul style="list-style-type: none"> 300kHz channel spacing 75kHz deviation |
| Narrow band channels – EUR | 6 | | | | <ul style="list-style-type: none"> 150kHz channel spacing 75kHz deviation Channel usage depends on application |
| Receiver sensitivity | | -102 | | dBm | <ul style="list-style-type: none"> Wideband US mode 152.34kbps data rate |
| | | -108 | | dBm | <ul style="list-style-type: none"> Wideband US mode 2.4kbps data rate |
| | | -110 | | dBm | <ul style="list-style-type: none"> Narrowband US mode 2.4kbps data rate |
| Receiver noise bandwidth | 200 | | | KHz | Wideband Mode |
| | 600 | | | KHz | Narrowband Mode |
| Adjacent Channel Rejection | | 55 | | dB | <ul style="list-style-type: none"> Chan+750kHz for wideband Chan+300kHz for narrowband |
| LO Leakage | | | -70 | dBm | |

AC Specifications - TX

| Parameter | Min | Typ | Max | Units | Notes |
|----------------------------|-----|-----|-----|-------|--|
| Transmit Frequency – US | 902 | | 928 | MHz | |
| Transmit Frequency – EUR | 868 | | 870 | MHz | |
| Wide band channels – US | | 32 | | | <ul style="list-style-type: none"> • 750kHz channel spacing • 235kHz deviation |
| Wide band channels – EUR | | 2 | | | <ul style="list-style-type: none"> • 400kHz channel spacing • 155kHz deviation • Channel usage depends on application |
| Narrow band channels – US | | 84 | | | <ul style="list-style-type: none"> • 300kHz channel spacing • 75kHz deviation |
| Narrow band channels – EUR | | 6 | | | <ul style="list-style-type: none"> • 150kHz channel spacing • 75kHz deviation • Channel usage depends on application |
| Transmit Power | | | +15 | dBm | • No SAW filter |
| | | | +12 | dBm | • With SAW filter |
| Harmonics | | | -55 | dBc | |

DC Specifications

| Parameter | Min | Typ | Max | Units | Notes |
|---------------|-----|-----|-----|-------|----------------------|
| RX current | | 14 | | mA | |
| TX current | | 54 | | mA | +15dBm power setting |
| TX current | | 34 | | mA | +10dBm power setting |
| TX current | | 27 | | mA | +5dBm power setting |
| TX current | | 22 | | mA | 0dBm power setting |
| Sleep Current | | .2 | 1 | uA | |

Functional Description

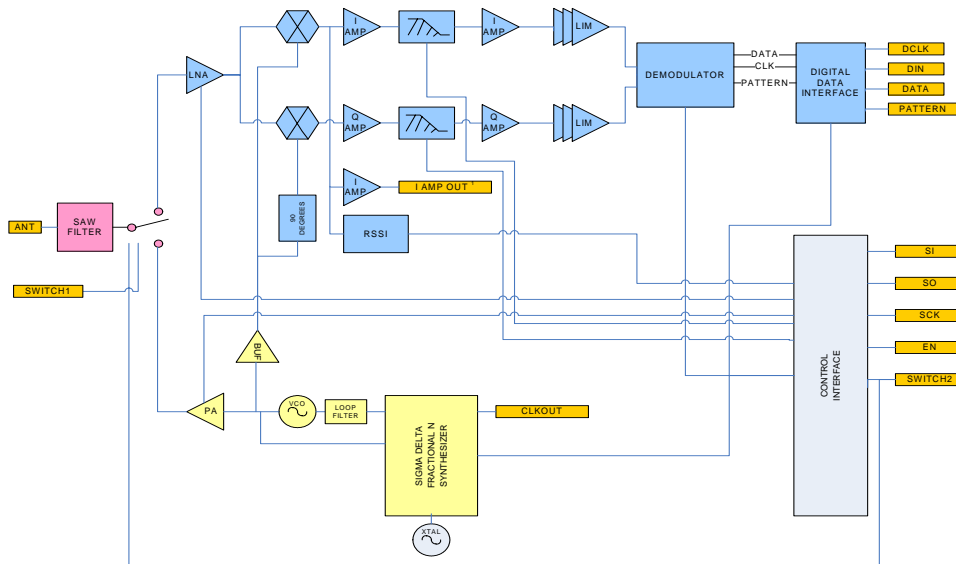

Figure 1: Block diagram of Wi.M900X/T module

The Wi.M900X/T module is based on the XEMICS XE1203E(F) transceiver RFIC. It encapsulates the remaining circuitry required to complete an RF module.

Any 50 ohm antenna can be used with the Wi.M900X/T.

The Wi.M900X module is populated with all of the transceiver components shown in figure 1. The Wi.M900T is only populated with the transmitter components; it does not have the SAW filter nor the RF switch.

On the Wi.M900X the antenna pin on the module goes either to the SAW filter or to the RF switch directly. The module can be ordered with or without a SAW filter. If the SAW filter is populated, it is critical that the antenna be AC coupled if it has a DC path to ground (which is true for most PCB antennas).

On the Wi.M900T the antenna pin connects directly to the output of the power amplifier.

If populated, the RF switch connects the antenna port to either the transmit or receive RF chain. It is controlled by SWITCH1 and SWITCH2. SWITCH2 is also connected to the SWITCH input of the XE1203. The following table shows how SWITCH1 and SWITCH2 affect the operation of the module.

| SWITCH1 | SWITCH2 | RF MODE | XE1203 REG SET |
|---------|---------|-----------------------|----------------|
| LOW | LOW | Receive – switch off | SWParam1 |
| HIGH | LOW | Receive | SWParam1 |
| LOW | HIGH | Transmit | SWParam2 |
| HIGH | HIGH | Transmit – switch off | SWParam2 |

Internally, the XE1203 has two identical sets of programming registers (SWParam) that control the operation of the chip. Generally, one set is programmed for receive mode and the other set is programmed for transmit mode. For the Wi.M900X/T module, set 1 is for receive mode and set 2 is for transmit mode.

For the Wi.M900T module, the register sets can be used to quickly switch between two frequencies. Register set 1 is selected when SWITCH2 is low, and register set 2 is selected when SWITCH2 is high.

In addition to the SWParam registers, there are three other register sets that set the operation of the module.

The ConfigSwitch register controls the operation of the SWITCH pin on the XE1203. Since we are using the SWITCH pin as an input, the value of ConfigSwitch does not matter.

The RTParam registers controls the operation of the radio itself. The FSParam registers controls the operation of the frequency synthesizer. The ADParam register determines the parameters of operation for the digital data interface. All of these registers are used in both receive and transmit mode. They can be programmed to meet the customer's needs. The only requirement is that bit 3 (RTParam_Switch_Ext) of RTParam must be set to 1.

The receive chain is a traditional zero-IF architecture. The filter bandwidth is programmable and can be set to 200kHz or 600kHz. RSSI is derived from the I-channel. It is digitized internally and can be read from the DataOut register.

Frequency error indication (FEI) is derived from both the I and Q channels. Its value can be read from the DataOut register. FEI can be used to correct for crystal frequency errors caused by temperature variations.

The demodulator re-creates the data stream. It demodulates the FSK modulated base-band carrier, extracts the bit stream timing, and samples the raw bit stream to accurately reproduce the original data.

In receive mode, the data interface is synchronous, operating as an SPI master. The module determines the data timing; the DCLK pin is the clock and the DATA pin is the data output.

In transmit mode, the data interface is asynchronous, operating as an SPI slave. The data timing is determined by the host microcontroller. The DCLK pin is not used in

transmit mode. The data input could be either DATA or DATAIN, depending on how the module is programmed.

Figure 2 shows a typical connection between the module and a host microcontroller SPI port. In this configuration, the DATA pin is programmed to be a data output in receive mode and a data output in receive mode. In receive mode, the microcontroller SPI port is configured as an SPI slave. The module generates data timing. In transmit mode, the microcontroller SPI port is configured as a SPI master. Timing is generated by the microcontroller.

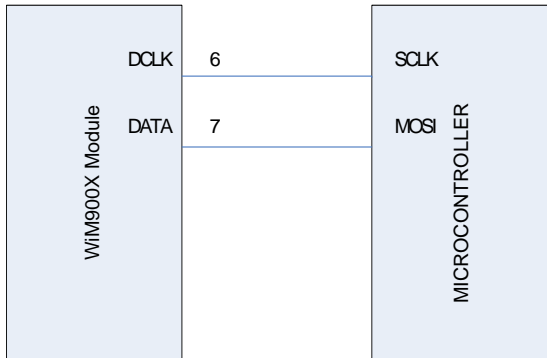

Figure 2

The transmit chain is essentially a VCO locked to a crystal reference frequency by a fractional N synthesizer. The synthesizer allows the VCO frequency to be set in 500Hz steps. It also supports direct digital FSK modulation of the transmit carrier. Frequency deviation can be set from 0 to 255kHz in 1kHz steps.

The output of the VCO is amplified by the power amp, which can be set to one of four output power levels.

For detailed information about programming the Wi.M900X/T module, please consult the current XE1203E(F) data sheet which can be found at www.xemics.com.

Programming Interface

The serial programming interface is compatible with any hardware or software implementation of a SPI serial port.

The following code example shows functions for reading and writing module registers using a software SPI implementation. The XE_SCLK, XE_SI, XE_SO, XE_EN definitions are hardware specific and correspond to the microcontroller IO pins that are connected to the XE1203 SPI pins.

```

//-----
// void halRFWriteReg(reg, val)
//
// Description:
//   Function used to write registers in the XE1203
//
// Arguments:
//           byte reg
//           Register number to write
//           byte val
//           Value to write to register
//
// Return value:
//   void
//-----
void halRFWriteReg(byte reg, byte val)
{
    byte data i;

    XE_SCLK=0;    // Always start in a low condition
    XE_SI=1;
    XE_EN=0;      // enable the serial port

    // start condition

    XE_SCLK=1;
    XE_SI=1;
    XE_SCLK=0;
    XE_SI=1;
    XE_SCLK=1;
    XE_SI=0; //
    XE_SCLK=0;
    XE_SI=0; // for delay only

    // write bit

    XE_SCLK=1;
    XE_SI=0;
    XE_SCLK=0;
    XE_SI=0; // for delay only

    for(i=0;i<=4;i++)
    {

        XE_SCLK=1;
        XE_SI=(reg&0x10);
        XE_SCLK=0;
        reg<<=1;
    }

    for(i=0;i<=7;i++)
    {
        XE_SCLK=1;
        XE_SI=(val&0x80);
        XE_SCLK=0;
        val=val<<1;
    }
    XE_SCLK=1;
    XE_SI=1;
    XE_SCLK=0;
    XE_SI=1;
    XE_SCLK=1;
    XE_SI=1;
    XE_SCLK=0;
    XE_EN=1;
    XE_SCLK=1;
    XE_SI=1;

```

```

        XE_SCLK=0;
    }

//-----
// void halRFReadReg(reg, val)
//
// Description:
//   Function used to read registers in the XE1203
//
// Arguments:
//   byte reg           Register number to write
//   byte val          Value to write to register
//
// Return value:
//   void
//-----
byte halRFReadReg(byte reg)
{
    byte data i;
    byte data regdat;

    regdat=0;

    XE_SCLK=0;    // Always start in a low condition
    XE_SI=1;
    XE_EN=0;      // enable the serial port

    // start condition

    XE_SCLK=1;
    XE_SI=1;
    XE_SCLK=0;
    XE_SI=1;
    XE_SCLK=1;
    XE_SI=0; //
    XE_SCLK=0;
    XE_SI=0; // for delay only

    // write bit

    XE_SCLK=1;
    XE_SI=1;
    XE_SCLK=0;
    XE_SI=1; // for delay only

    for(i=0;i<=4;i++)
    {

        XE_SCLK=1;
        XE_SI=(reg&0x10);
        XE_SCLK=0;
        reg<<=1;
    }

    for(i=0;i<=7;i++)
    {
        regdat=regdat<<1;
        XE_SCLK=1;
        regdat|= (byte)XE_SO;
        XE_SCLK=0;
    }
    XE_SCLK=1;
    XE_SI=1;
    XE_SCLK=0;
    XE_SI=1;
    XE_SCLK=1;
    XE_SI=1;
    XE_SCLK=0;
}

```

```

XE_EN=1;
XE_SCLK=1;
XE_SI=1;
XE_SCLK=0;

return  regdat;

}

```

Non-volatile memory

The on-board nonvolatile memory stores a 48-bit unique identification number and a signed 8-bit calibration constant.

The calibration constant is used to correct the channel programming for offset error caused by the reference crystal. The following code snippet shows how to use this constant:

```

void halRFSetChan(byte chan)
{
    int    offset, txword, rxword;

    txword=chanDTS[chan];
    rxword=chanDTS[chan];

    // Read offset. If the XTCAL value is below min or above max, it will
    // default to 0 (no offset).
    // -----
    offset = (int)i2cRead(NV_XTCAL);
    if ((offset < XTCAL_LOWER_LIMIT) || (offset > XTCAL_UPPER_LIMIT))
        offset = 0;

    // Set the transmit parameters
    // -----
    txword+=offset;
    halRFWriteReg(rfrSWPARAMB_2,(byte)txword);
    halRFWriteReg(rfrSWPARAMB_1,(byte)(txword>>8));

    // Set the receive parameters
    // -----
    rxword+=offset;
    halRFWriteReg(rfrSWPARAMAMA_2,(byte)rxword);
    halRFWriteReg(rfrSWPARAMAMA_1,(byte)(rxword>>8));
}

```

The channel programming word is determined by chanDTS[channel]. The calibration constant is then read in using the I2C bus; it is stored in offset. The offset is then added to the channel programming word and sent to the Wi.M900X/T module using the programming interface.

Example circuit

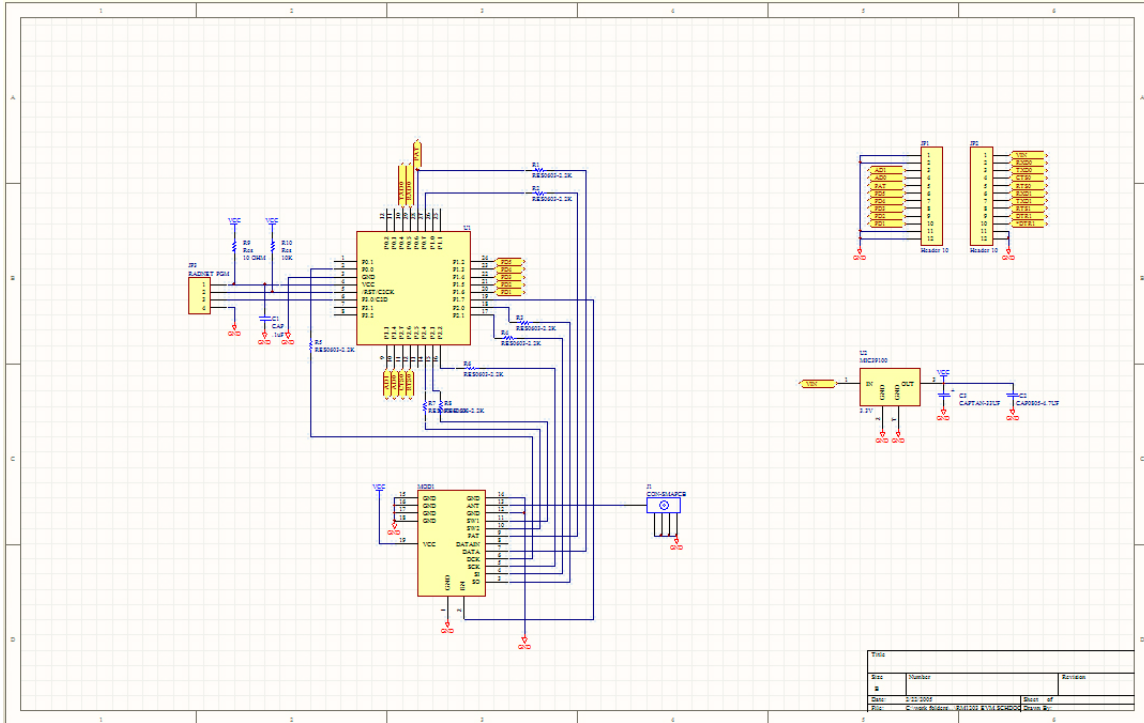

Figure 3: Example schematic

Ordering Information

| PRODUCT ORDER CODE | DESCRIPTION |
|--------------------|--------------------------------|
| Wi.M900X-R | US transceiver version |
| Wi.M868X-R | European transceiver version |
| Wi.M900T-R | US transmit only version |
| Wi.M868T-R | European transmit only version |

Contact Information

Corporate Headquarters:
905 Messenger Lane
Moore, Oklahoma 73160
405-794-7730

website: www.radiotronix.com
support: support@radiotronix.com