

**128 channel, Half-Duplex 868/915 MHz
76.8 kbit/sec FSK Data Transceiver**

Typical Applications

- Asset Tracking
- Wireless Sensors
- Home Automation
- Remote Control
- Automated Meter Reading
- Remote Data Acquisition
- Building Automation

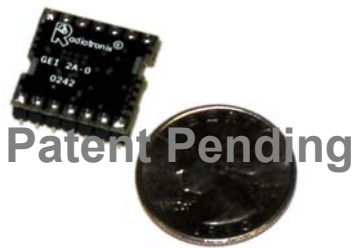

Features

- 500+ feet of range (outdoors line-of-sight)
- 3V very low-power operation
- .3 to 76.8 kbit/second data rate
- No special encoding required to use with UART
- Small DIP form-factor - .7" x .7" x .15"
- Unlicensed operation in the US and UK
- Factory set 32-bit unique ID is perfect for network applications
- Very Low Cost in Large Volumes
- Development tools including API source code available

Description

The EWD-900-FDTC is a fully integrated half duplex wireless FSK data transceiver. The basic design of the transceiver is frequency-scaleable from 300MHz to 1GHz, allowing operation in countries around the world. The transceiver can operate on 128 channels in the 902-928MHz unlicensed band. It contains built in data encoding and decoding, simplifying the interface and software of the host processor. A typical circuit will consist of a low-cost microcontroller, a power source, and an antenna. The transceiver requires no external RF components with the exception of a 50-ohm antenna.

Summary Electrical Specifications

Preliminary

Parameter	T _a =25°C			Units
	Min.	Typ.	Max.	
Operating Frequency - US	902	915	928	MHz
Channels – US operation	128			
Operating Frequency – UK	868		870	MHz
Channels – UK operation	20			
TX Output Power		0	5	dBm
RX Sensitivity(900MHz) 600 baud Manchester		-97.6		dBm
RX Sensitivity(868MHz) 600 Baud Manchester		-100.6		dBm
Operating Voltage	2.7	3.0	3.3	VDC
Operating Current-TX 0dBm		16		mA
Operating Current-TX 4dBm		24		mA
Operating Current-RX		9.8		mA
Data Rate	0.6		76.8	Kbit/sec
TX-RX Switch Time		150		uSec

Document Control

Created By	Steve Montgomery	10/30/02
Engineering Review		
Marketing Review		
Approved - Engineering		
Approved - Marketing		

Revision History

Revision	Author	Date	Description
1.0	SJM	10/30/01	Document Created
1.1	SJM	11/18/02	Module pin-out diagram and table corrected

Table of Contents

Typical Applications	<i>i</i>
Summary Electrical Specifications	<i>i</i>
Features	<i>i</i>
Description	<i>i</i>
Document Control	<i>ii</i>
Revision History	<i>ii</i>
Table of Figures	<i>iii</i>
Pin Out Diagram	1
Pin Description	1
Mechanical Drawing	2
Absolute Maximum Ratings	2
Detailed Electrical Specifications	2
AC Specifications – RX.....	2
AC Specifications – TX.....	3
AC Specifications – System Timing.....	4
DC Specifications	4
Circuit Description	5
Example Application Circuit	7
Related Documentation	8
Ordering Information	8

Table of Figures

Figure 1: Mechanical Drawing of EWD-HDTC.....	2
Figure 2 EWD-HDTC Internal Block Diagram.....	5

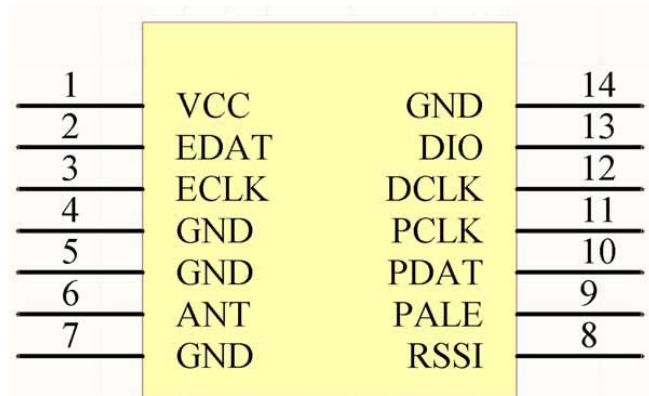
Pin Out Diagram**Pin Description**

Pin No.	Pin Name	Description
1	VCC	Power Supply
2	EDAT	EEPROM Data Line – I2C interface
3	ECLK	EEPROM Clock Line – I2C interface
4	GND	Ground
5	GND	Ground
6	ANT	50-ohm antenna port
7	GND	Ground
8	RSSI	Analog RSSI Output
9	PALE	Programming interface ALE
10	PDAT	Programming interface data input/output
11	PCLK	Programming interface clock input
12	DCLK	Data interface clock
13	DIO	Data interface input/output
14	GND	Ground

Mechanical Drawing

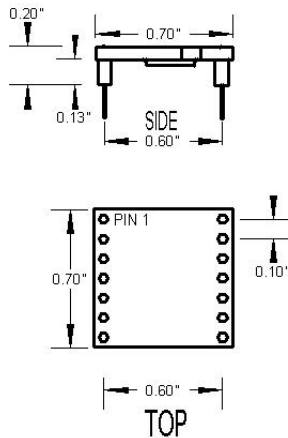

Figure 1: Mechanical Drawing of EWD-HDTC

Absolute Maximum Ratings

Parameter	Min	Max	Units
VCC – Power Supply	-0.3	5.0	VDC
Voltage on any pin	-0.3	VCC+.3, 5.0 MAX	VDC
Input RF Level		10	dBm
Storage Temperature	-50	150	°C
Operating Temperature	0	70	°C

Detailed Electrical Specifications

AC Specifications – RX

Parameter	Min	Typ.	Max	Units	Notes
Receive frequency - US	902.2		927.8	MHz	At antenna pin
Channels - US	128				
Input Frequency - UK	868		870	MHz	At antenna pin
Channels - US	20				
Channel spacing – US		200		kHz	
Channel spacing - UK		100		kHz	
Receiver sensitivity		-97.6	-93	dBm	900 MHz 600 baud manchester
Receiver sensitivity		-100.6	-93	dBm	868 MHz 600 baud manchester
Receiver noise bandwidth		30		kHz	
Cascaded noise figure		13		dBm	

Maximum input power	10			dBm	2.4kBaud Manchester encoded data, BER=10 ⁻³
Input IP3		-18		dBm	2.4kBaud Manchester encoded data, BER=10 ⁻³
Input Impedance		50		Ohms	No matching required
LO Leakage		-57		dBm	50-ohm termination at ANT
Adjacent channel rejection		TDB40		dBc dBc	Fc +/-200kHz
Intermediate Frequency (IF)		150		KHz	
IF Bandwidth		175		KHz	
RSSI Dynamic Range	-105		-50	DBm	
RSSI Accuracy		±6		DB	
RSSI Linearity		±2		DB	
Turn-on time	11		128	Bauds	Turn-on time is determined by demodulator settling time

AC Specifications – TX

Parameter	Min	Typ.	Max	Units	Notes
Transmit Frequency -US	902.2		927.8	MHz	
Channels - US	128				
Channel Spacing - US		200		kHz	
Transmit Frequency -UK	868		870	MHz	
Channels - UK	20				
Channel Spacing - UK		100		kHz	
Center frequency error		5	10	ppm	915 MHz, 25°C, using calibration data from EEPROM
Data Rate	.3		76.8	kBit/sec	
Frequency Deviation	0		65	kHz	Fdev is set corresponding to data rate
Output Power	-20	-1.3	5	dBm	900 MHz Into 50 ohm load
Output Power	-20	-0.7	5	dBm	868 MHz Into 50 ohm load

Output Impedance		50		Ohms	
Carrier phase noise		-85		dBc	Into 50 ohm load
Harmonic Output		-20 -40		dBc dBc	Into 50 ohm load

AC Specifications – System Timing

Parameter	Min	Typ.	Max	Units	Notes
Turn-on time - TX		TBD		mSec	
Turn-on time – RX		TBD		mSec	
Wake-up time		TBD		uSec	Wake-up from sleep
TX->RX switch time		TBD		uSec	
RX->TX switch time		TBD		uSec	
Channel Change Time		200		uSec	Up to 1MHz frequency step

DC Specifications

Parameter	Min	Typ.	Max	Units	Notes
Supply voltage	2.1	3.0	3.6	VDC	Operating limits
Receive current consumption		9.6 96		mA uA	Continuous operation Polled operation
Transmit current consumption Po= -20 dBm Po= -5 dBm Po= 0 dBm Po= 5 dBm		8.6 13.8 16.5 25.4		mA mA mA mA	Output into 50 ohm load
PLL only current consumption		6		mA	
Power down current consumption		0.2	TBD	uA	
Vih – Logic high level input	0.7*Vcc		Vcc	VDC	
Vil – Logic low level input	0		0.3*Vcc	VDC	
Voh – Logic high level output	2.5		Vcc	VDC	
Vol – Logic low level output	0		.4	VDC	

Circuit Description

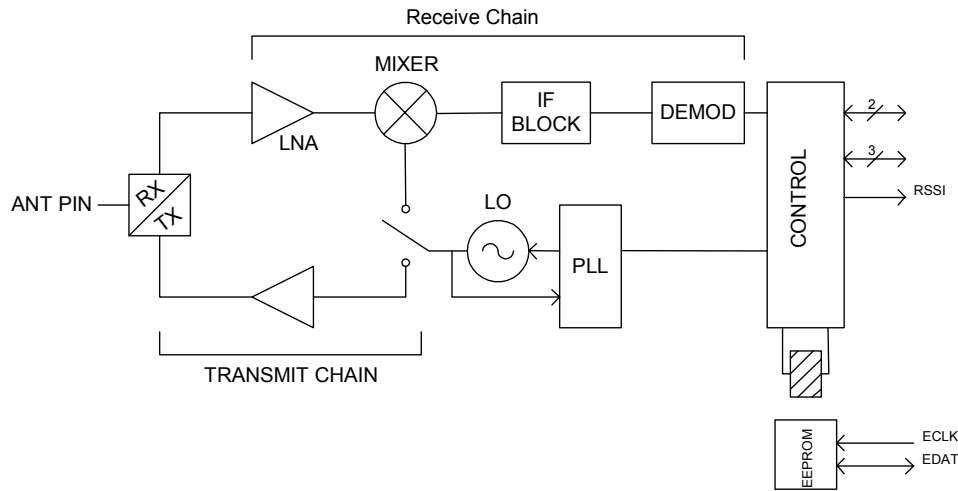

Figure 2 EWD-HDTC Internal Block Diagram

A simplified block diagram of the EWD-HDTC module is shown in Figure 2.

The module contains an internal antenna switch, and can operate in one of four modes: TX, RX, sleep, and shutdown.

In transmit mode, the local oscillator (LO) is switched to the power amp (PA), generating the transmit carrier. The PLL provides closed-loop frequency control of the carrier. The incoming data stream is used to frequency modulate the carrier. Modulation is precisely controlled by the PLL by switching between two reference frequencies corresponding to the two possible states of the data input line. Data can be transmitted in NRZ or Manchester form. The control block contains a built-in Manchester encoder, simplifying the requirements of the external microcontroller.

In receive mode, the module operates like a traditional super heterodyne receiver. The LO is switched to the receive mixer in order to down convert the incoming RF signal to a 150 kHz intermediate frequency. The IF block amplifies and filters the down converted signal in preparation for demodulation. Clock extraction and synchronization is performed on the demodulated data by the control block. The receiver supports NRZ and Manchester encoded data.

The on-board PLL allows fine-frequency adjustments to be made to the carrier frequency, eliminating the need for on-board trimmer capacitors and temperature controlled crystal oscillators.

A unique feature of the module is the on-board EEPROM. The EEPROM contains a unique 32-bit serial number and calibration data. The calibration data is used to correct for frequency errors generated by the crystal and by temperature deviation from 25 degrees C. For more information on using information from the EEPROM, please refer to "EWD-HDTC USER'S MANUAL".

The EWD-HDTC provides a very simple microcontroller interface. The module is programmed by a 3-wire serial interface, and data is sent and received to and from the module using a 2-wire serial interface. The RSSI pin provides an analog voltage that is proportional to the incoming received signal in dB.

Programming the EWD-HDTC is very simple. We provide a complete API for most microcontrollers that is written in C. For details on the API please refer to "EWD-HDTC USER'S MANUAL".

Related Documentation

- EWD-HDTC USER'S GUIDE (Available November 21, 2002)

Ordering Information

PRODUCT	ORDER CODE
EWD-900-HDTC	100-900-06A