

RCT-xxx-AS(B) and RCR-xxx-RP Design Hints.

By Gordon Hudson

Transmitter Section:

(RCT-xxx-AS[B])

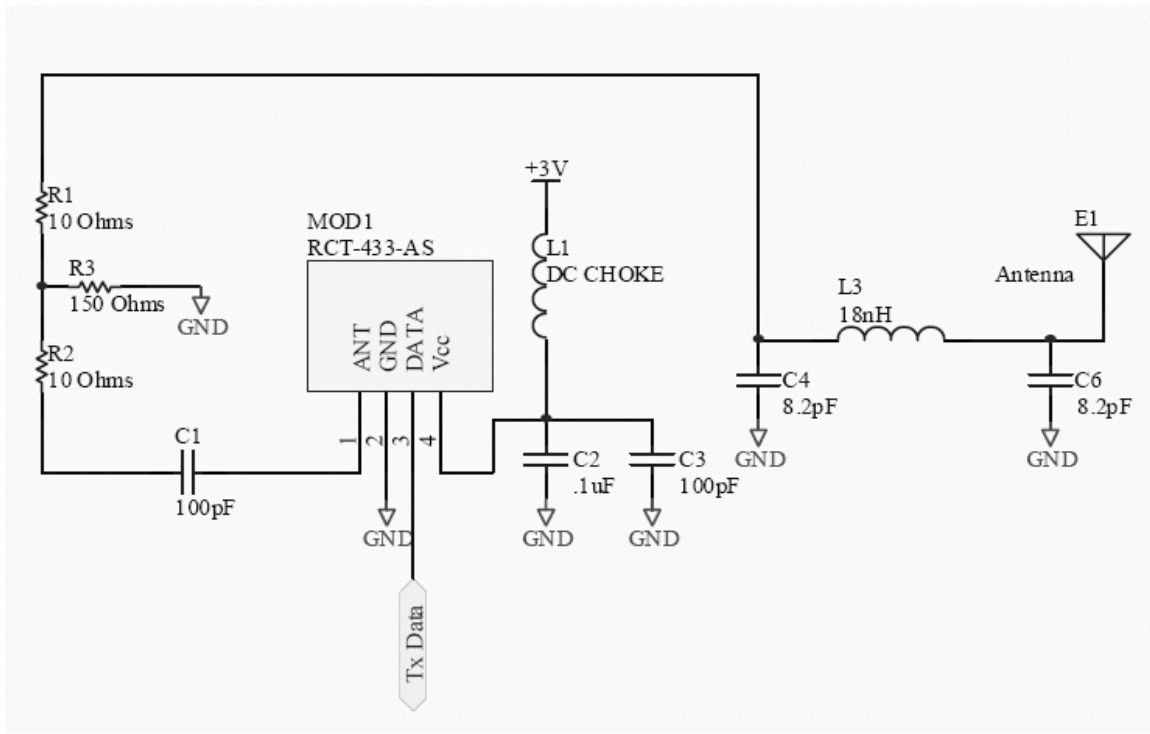

Description:

MOD1

L1, C2, C3

C1

R1, R2, R3

C4, C6, L3

RCR-433-AS Transmitter.

Power supply noise filter & bypass.

Transmitter output DC block.

Transmitter T-PAD match & attenuator.

Low pass, harmonic filter.

In depth:

Power supply noise filter & bypass.

The power supplied to the transmitter module must be stable and noise free. L1 usually is a ferrite bead inductor or some other inductor tuned to block a known on-board interference source. C2 and C3 provide a route to ground for any additional noise. These can also be tailored to suit the application.

Transmitter output DC block.

The transmitter output from the RCR-xxx-AS(B) series of modules is DC biased. Eliminating this part will cause a short circuit to ground through the T-PAD circuit. This part should also be used to avoid the presence of DC in the antenna and to provide extra reliability in designs which do not utilize a T-PAD.

Transmitter T-PAD match & attenuator.

The RCT-xxx-AS(B) is very sensitive to unbalanced or unmatched loads and will fail to operate or operate intermittently if such a load is used. The impedance presented to the transmitter must be close to 50Ω.

The T-PAD circuit helps the transmitter to “see” 50Ω in applications where the antenna may not be as close to 50Ω as it should. The T-PAD circuit also adds attenuation. The values in the example provide approximately 3dB of attenuation and can be modified to suit the application.

Low pass, harmonic filter:

In order to help pass FCC/ETSI emissions testing and to possibly help antenna tuning, a low pass filter can be added to attenuate radiated RF harmonics.

The values provided in this example are figured on the basis that your antenna is 50Ω impedance. They probably will require adjustment due to the design variables of your product - board layout, trace impedance, trace-to-trace coupling and capacitance, proximity to devices, shields, cases, etc.

Receiver Section:

(RCR-xxx-HP) – also applies to RCR-xxx-RP and MP

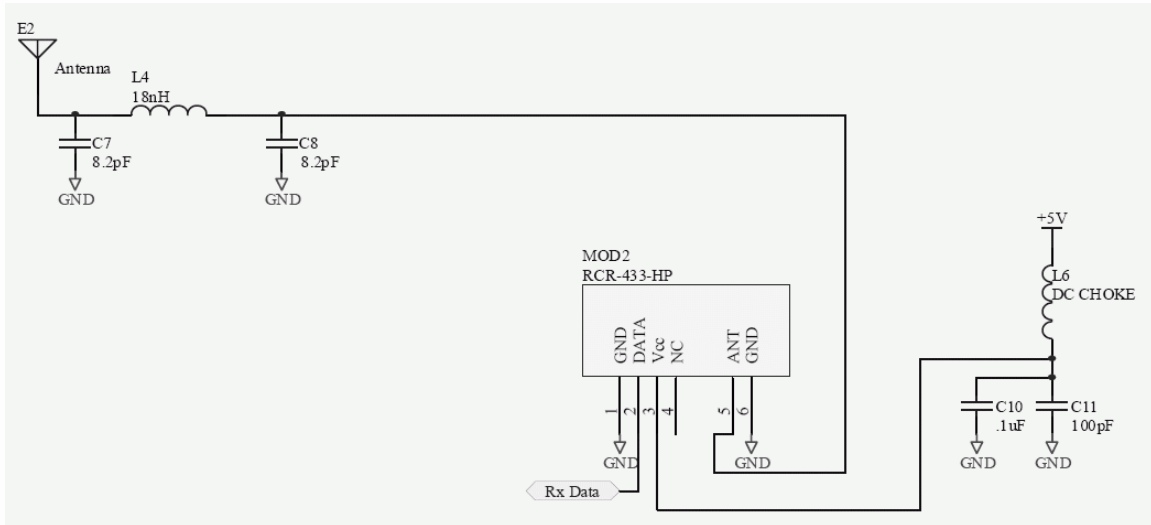

Description:

MOD1
L6, C10, C11
C7, C8, L4

RCR-433-HP Receiver.
Power supply noise filter & bypass.
Low pass, harmonic filter.

In depth:

Power supply noise filter & bypass.

It is critical that the power supplied to the receiver module is stable and particularly noise free. Noise on the power supply can often severely degrade receiver sensitivity which translates in a real-world situation to poor range.

L6 usually is a ferrite bead inductor or some other inductor tuned to block a known on-board interference source. C10 and C11 provide a route to ground for any additional noise. These can also be tailored to suit the application.

Low pass, harmonic filter:

The function of the low pass filter in the receiver is to provide a more “selective” front-end to the receiver by attenuating any transmissions or interference sources above the frequency of operation.

A band pass filter can be utilized to provide more selectivity.

The values provided in this example are figured on the basis that your antenna is 50Ω impedance. They probably will require tweaking due to the design variables of your product - board layout, trace impedance, trace-to-trace coupling and capacitance, proximity to devices, shields, cases, etc, will have to be taken into account.

PCB Trace Antenna design:

(applies to both transmitter and receiver designs)

Although it is a popular option in embedded design, PCB trace antenna design and tuning is not a trivial subject. It requires specialized equipment such as a Vector Network Analyzer. The tuning of the antenna would be a "guesstimate", at best, if access to a VNA is not possible. If the receiver antenna impedance match is not 50Ω at your chosen frequency, you will see poor range and receiver sensitivity loss. On the transmitter side, it is possible that the transmitter will not start up, start intermittently, oscillate or drift off frequency. Often, the quickest route is to use an off-the-shelf 50Ω antenna.

Gordon Hudson,
RF Engineer
Radiotronics, Inc.

For Technical Support:

Lillian Kioko
RF Technician
lkioko@radiotronics.com
(405) 794-7730